

Description:

For this project we will be using Rhino and the 3-Axis CNC mill to create plaster molds for slip-casting. To be even more specific we will actually be using the 3-Axis CNC mill to carve “Master Molds” (or molds for the mold parts) out of Styrofoam sheets.

Parting Lines and Parting Planes

Let’s start by creating and laying out the mold parts for a simple sphere. The first thing we have to think about is the “**parting line**”. This is a line that runs along the surface of a form where the two parts of our mold will come together. We’ll use this parting line to create a “**parting plane**” - the surface that separates the two parts of our mold.

This sphere has a very clear **parting line** that runs right through the middle of the form:

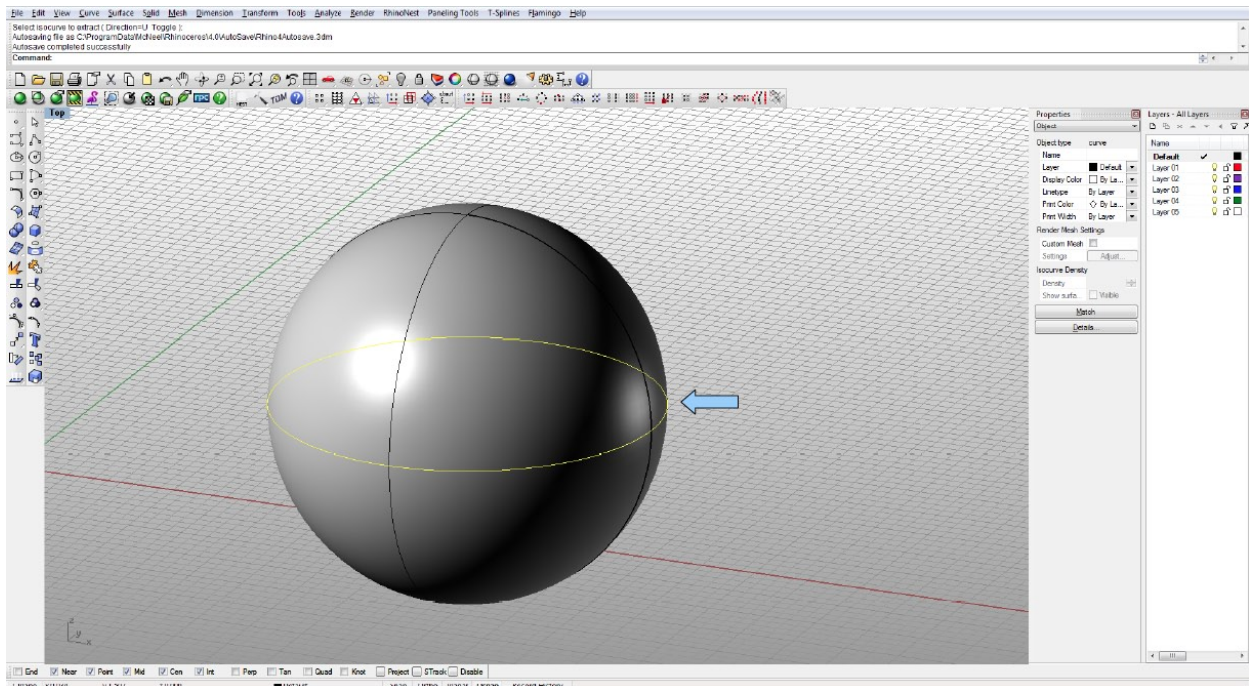

The parting line for this form is also “planar” which means our parting plane will also be a flat surface.

Resources: Parting Plane Logic - 2 Part Molds (Rhino + CNC Mill)

To create the parting plane you can draw a second curve defining the outer boundary of your mold. ****For slip-casting molds it is important to have at least 1.5" between your object and the outer surface of the mold.**

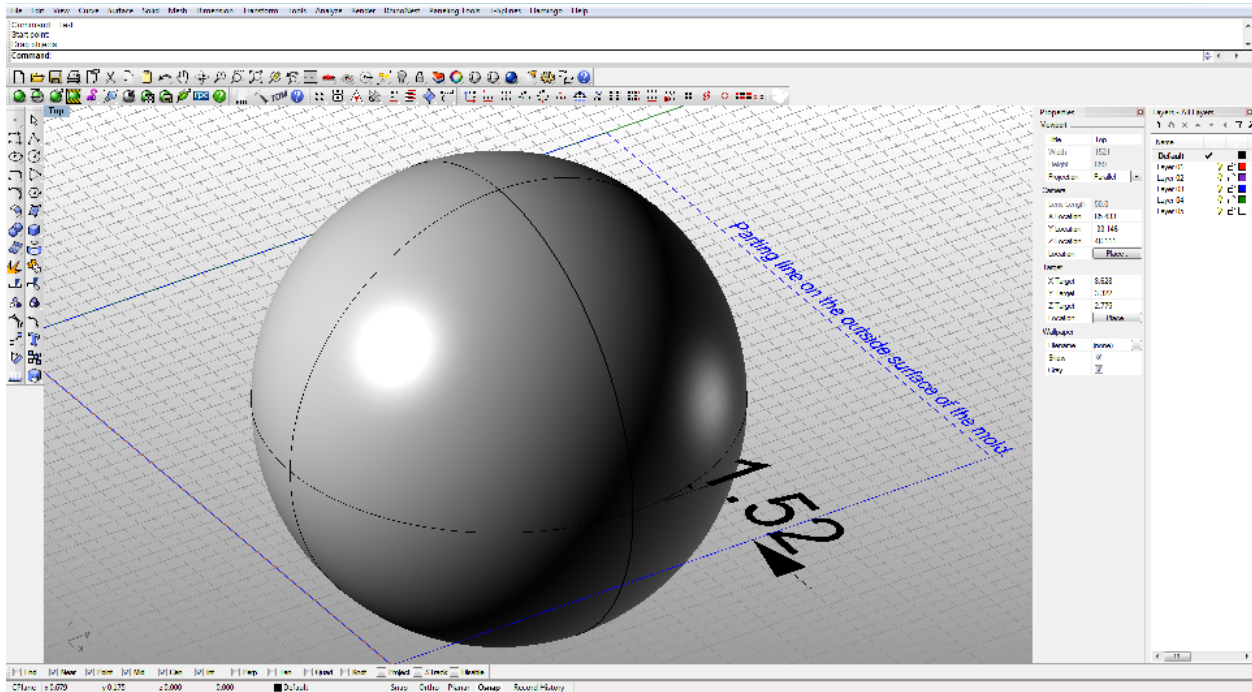

Now I can create a parting plane by lofting a surface between the two parting lines:

select both lines --> **surface menu --> loft** or type **_Loft** in the command line:

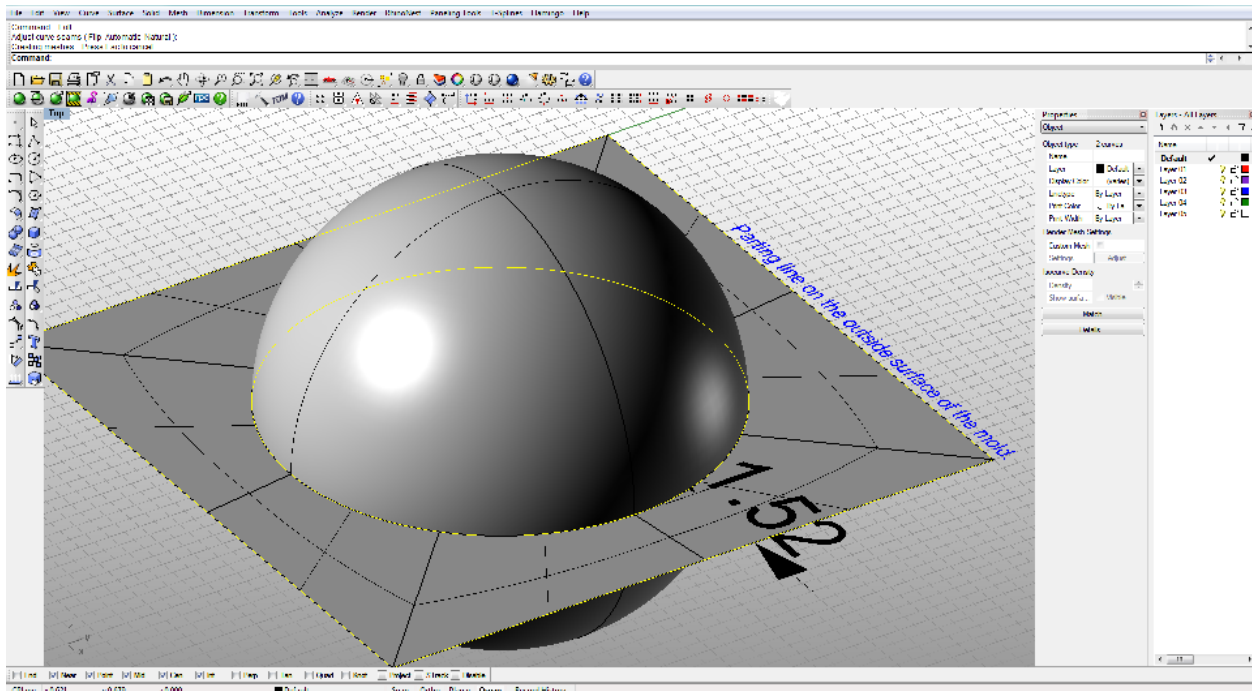

Resources:

Parting Plane Logic - 2 Part Molds (Rhino + CNC Mill)

Registration Keys:

Because the parting plane for this mold is flat it is important to build in some kind of registration keys so that the two sides of the mold will stay properly aligned when casting. ****When using pottery plaster these keys should be at least $\frac{3}{4}$ " in diameter to keep them from breaking off in the mold.**

We'll create these keys by drawing a sphere on the surface of the parting plane and defining the radius as $\frac{1}{2}$ " (**Solids – Sphere – Center to Radius** or **_Sphere** in the command line). Then copy the sphere to a few more places making sure that it stays aligned with its mid-point on the parting plane (**Transform Menu – Copy** or **_Copy** in the command line). ****It's a good idea to create an arrangement of keys that is asymmetrical so it's easy to keep track visually of how the mold goes back together:**

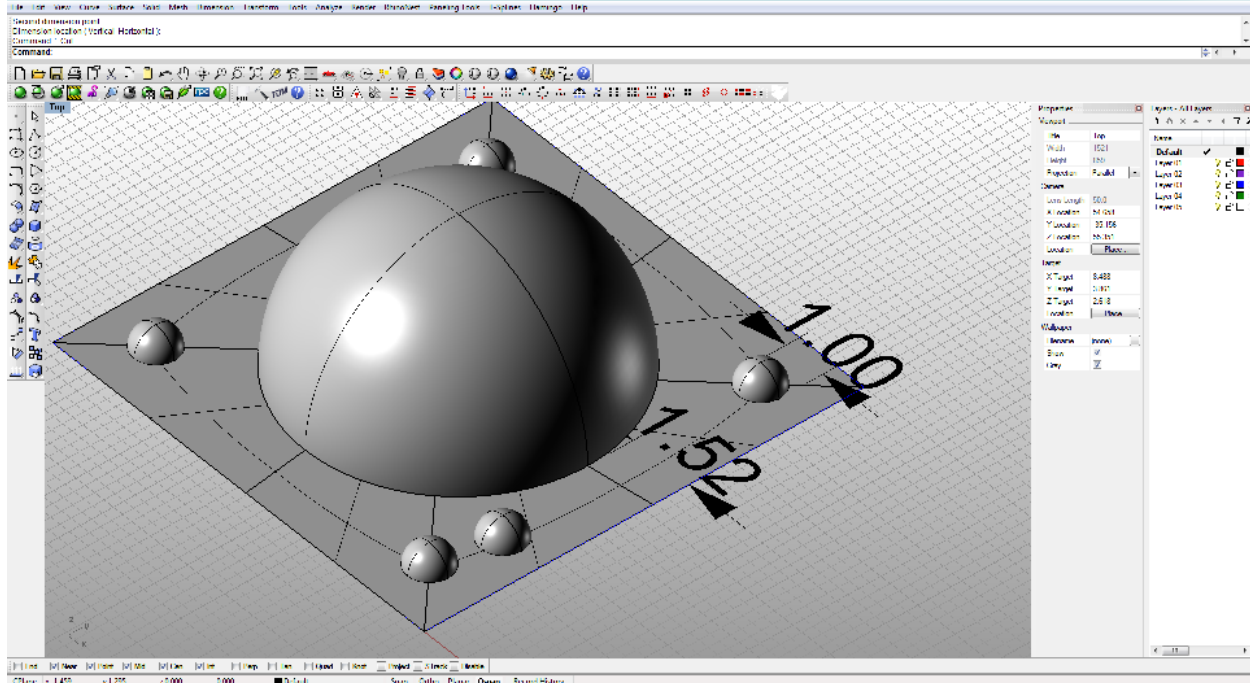

Resources: Parting Plane Logic - 2 Part Molds (Rhino + CNC Mill)

Part 2 of the Mold:

This is the first part of your master mold. Now we need to create the second half of the mold. First build a box the size of the outer dimensions of the second half of the mold (**Solid Menu – Box – Corner, Corner, Height**) :

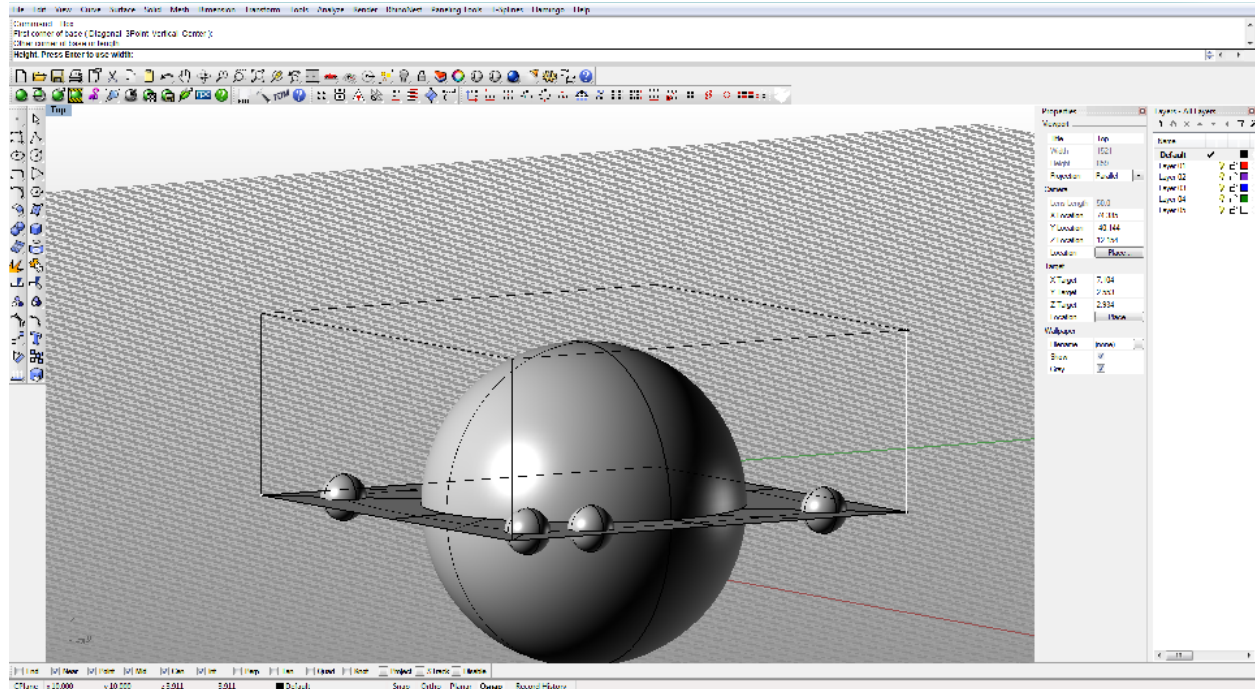

Resources: Parting Plane Logic - 2 Part Molds (Rhino + CNC Mill)

Now we want to create the negative of our registration keys in the second half of our mold. We'll do this using the boolean command.

First select all of your keys and group them together (**_Group**). Then make a copy of the keys (**Select** the keys - **Ctrl+C**, **Ctrl+V**). Now de-select the keys and use the boolean difference command to "cut" the keys out of the second half of the mold (**_BooleanDifference** – select the box defining the second half of your mold and press **enter** – then select the copy of your grouped keys and press **enter**).

Now when you select the second mold half you can see the negative shape of the keys in that half of the mold:

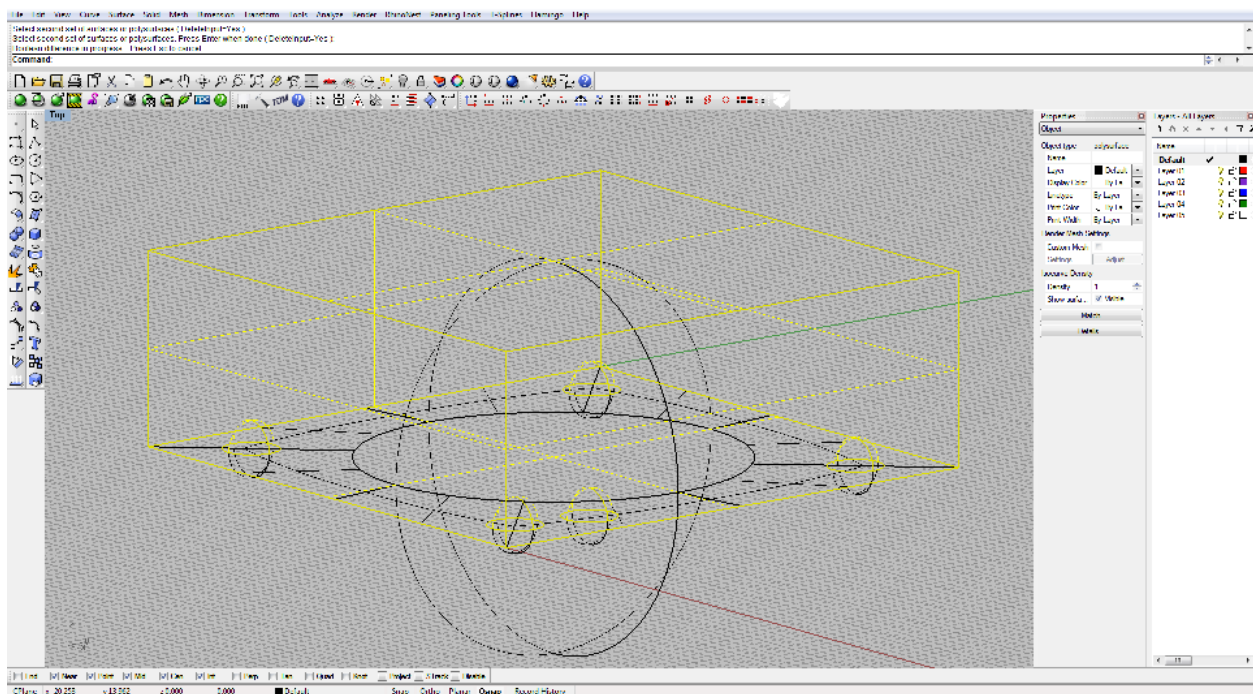

Now all that's left is to lay out the second half of the mold for the mill by flipping it over. When we do this we want to keep a copy of our object with the second half so first select the sphere and make a copy (**Ctrl+C**, **Ctrl+V**). To make sure these parts stay together you can now select that second half of the mold along with the copy of your object and group them together (**_Group**).

You can flip the second half of the mold:

1. First change views to the **Front Viewport**
2. Then use the **Transform Menu – Rotate** command (**_Rotate** in the command line).
3. Select the bottom right corner of part 2 of your mold and rotate 180 degrees around the Y Axis (hold down the shift button to constrain the rotation at 90 degree intervals).

Resources: Parting Plane Logic - 2 Part Molds (Rhino + CNC Mill)

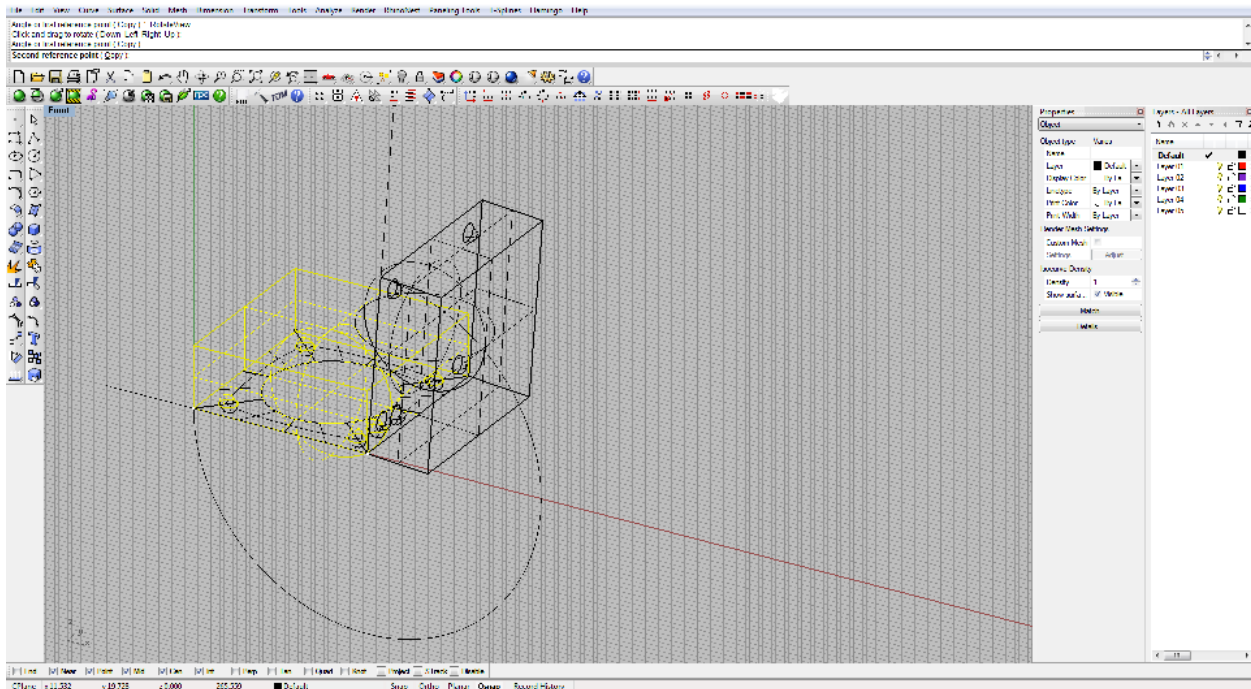

There you go! Now the two parts of the mold are all laid out and ready for the mill:

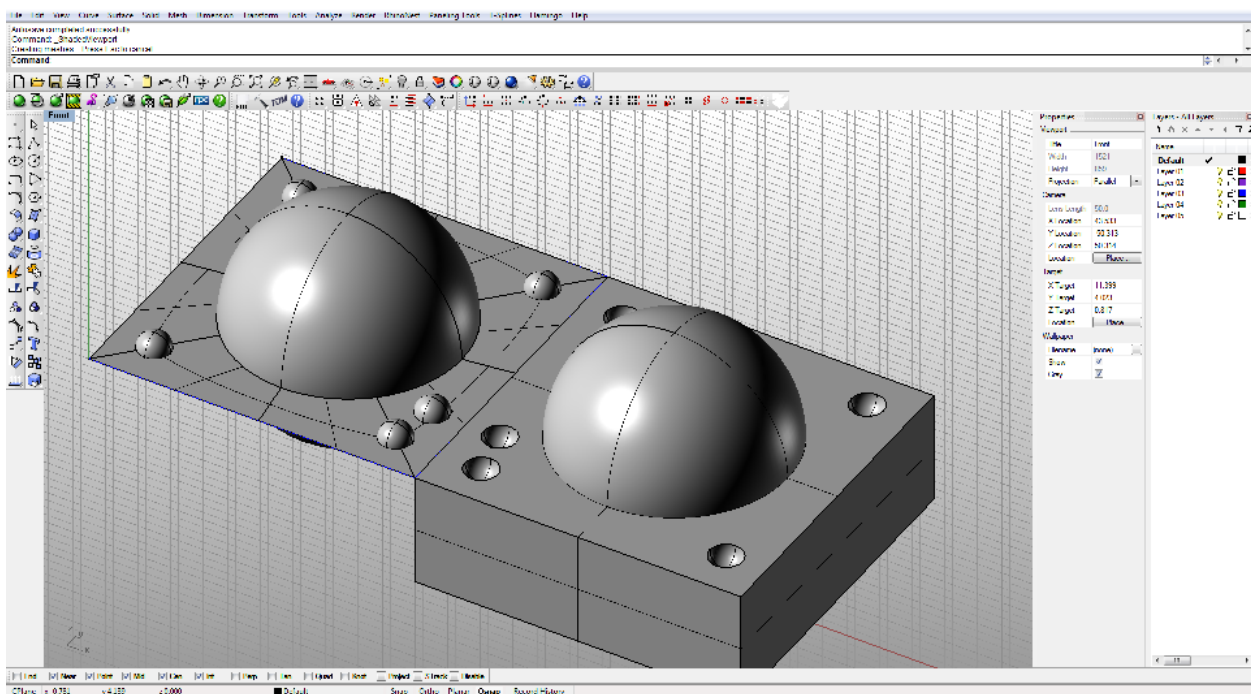

Creating Non-Planar Parting Lines:

In many cases the object you want to create a mold of may have a parting line that is not flat (**non-Planar**). We'll start this example with a more irregular shape made by creating a pipe around a non-planar curve:

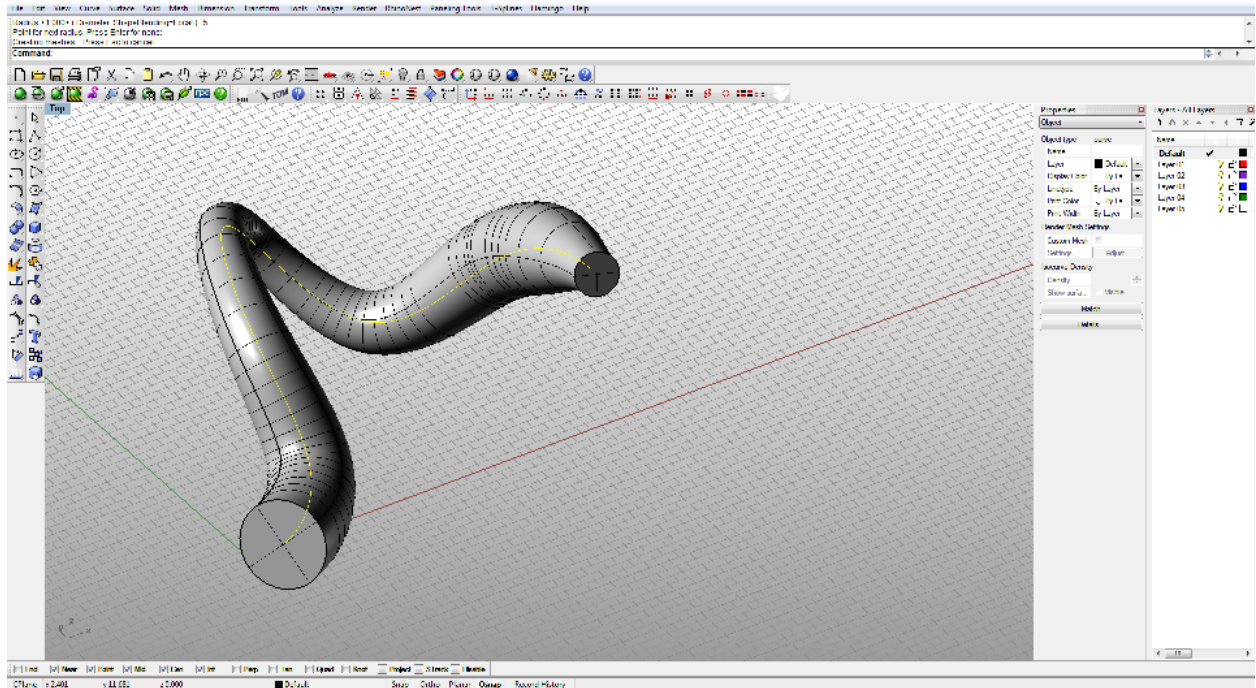

Split Mesh by Draft Angle:

There is a fairly efficient command for finding the parting line for a mesh. In order to use that we'll first need to convert this object into a mesh (**select** the surface and then **_Mesh** in the command line). To keep things simple I'm going to create a fairly low resolution mesh:

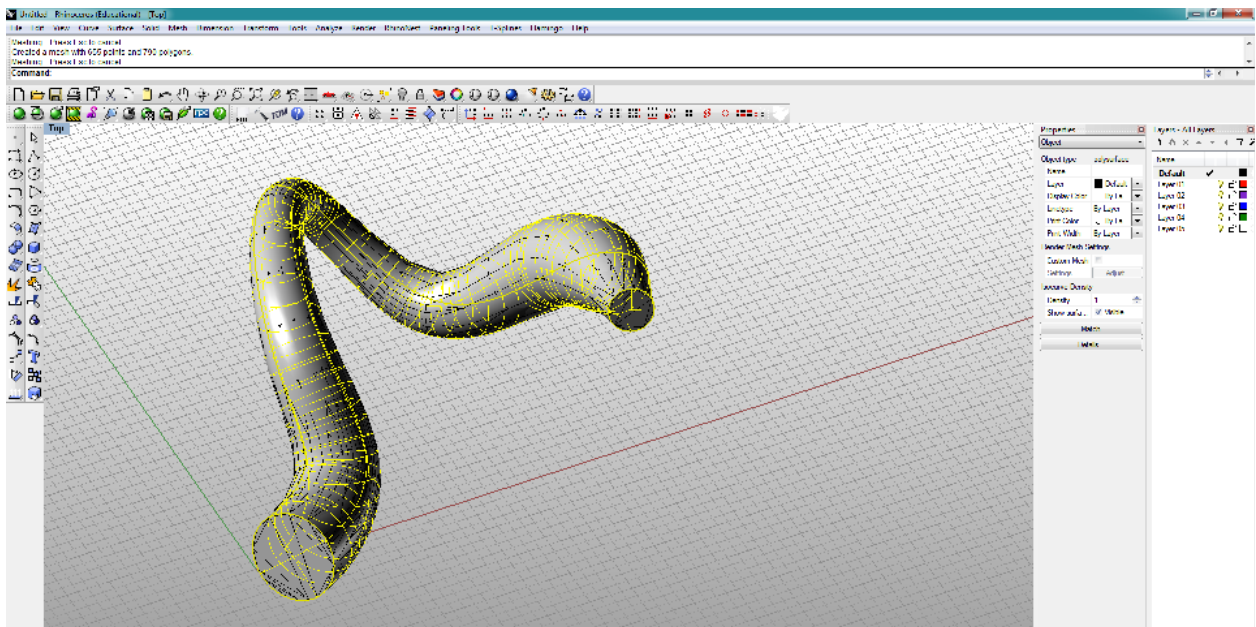

Resources: Parting Plane Logic - 2 Part Molds (Rhino + CNC Mill)

I can now find the parting line by using the **Extract Mesh Faces by Draft Angle** command (**Mesh Menu - Mesh Edit - Extract Mesh Faces - By Draft Angle**). Make sure you are in the **Top view**, "**Start Angle from Camera Direction**" should be **0** and "**End Angle from Camera Direction**" should be **89**. Now check the "**Border Only**" box in the popup window to create a curve around the parting line:

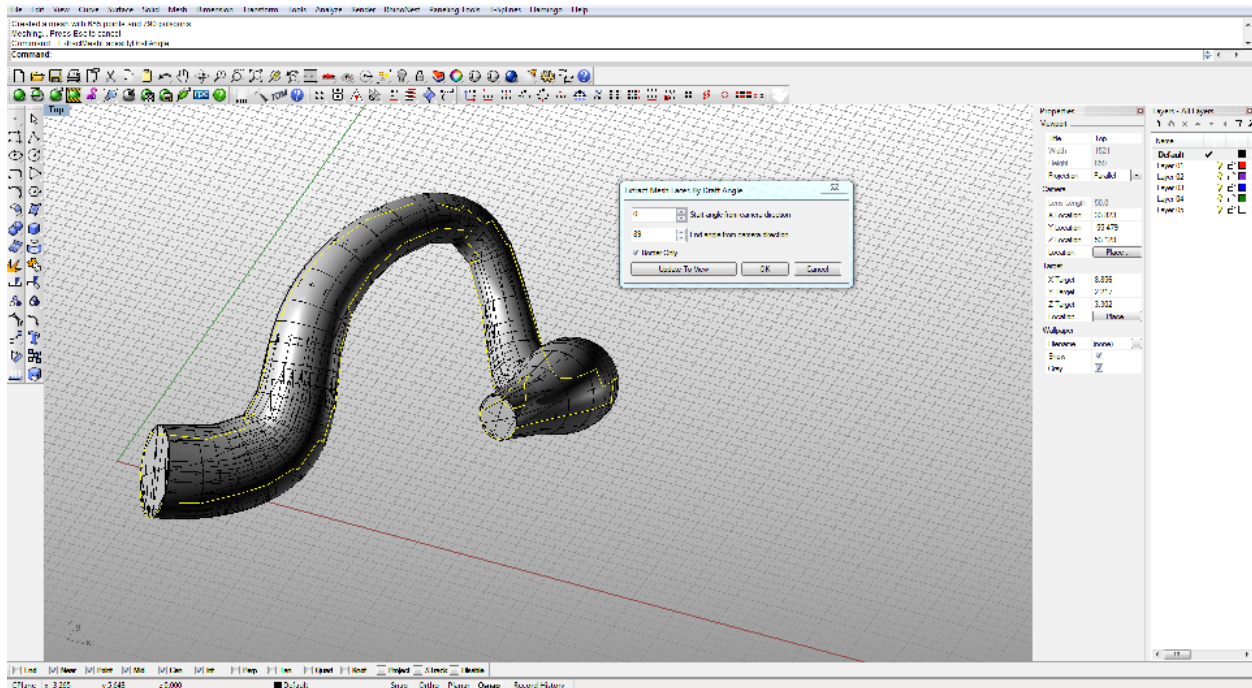

This is roughly the parting line but in order to make it really functional it's typical that some editing has to be done. If I zoom in I can see there are some places where the parting line "**fold back on itself**":

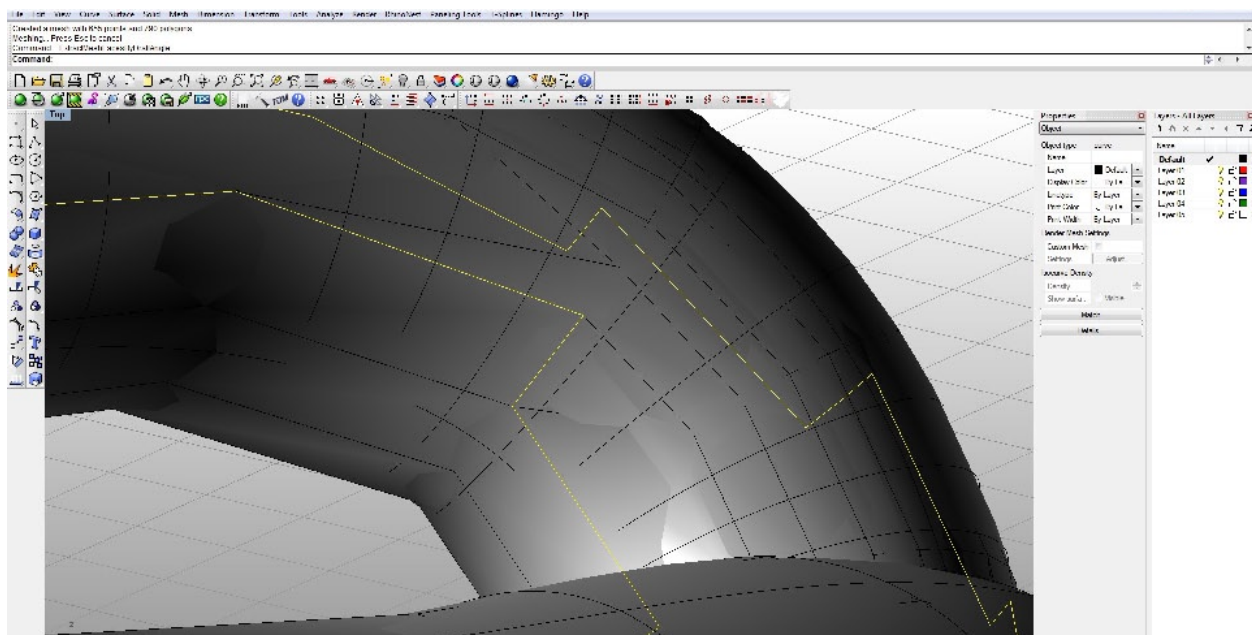

This will ultimately create a place in the parting plane that will potentially lock the two halves of the mold together.

Resources: Parting Plane Logic - 2 Part Molds (Rhino + CNC Mill)

We can fix this by splitting the parting line, drawing a new curve that doesn't "fold back on itself", and then re-connecting the parting line into a new curve. It's a bit "surgical" and can get tedious. You can see the benefit now of creating a lower resolution mesh!

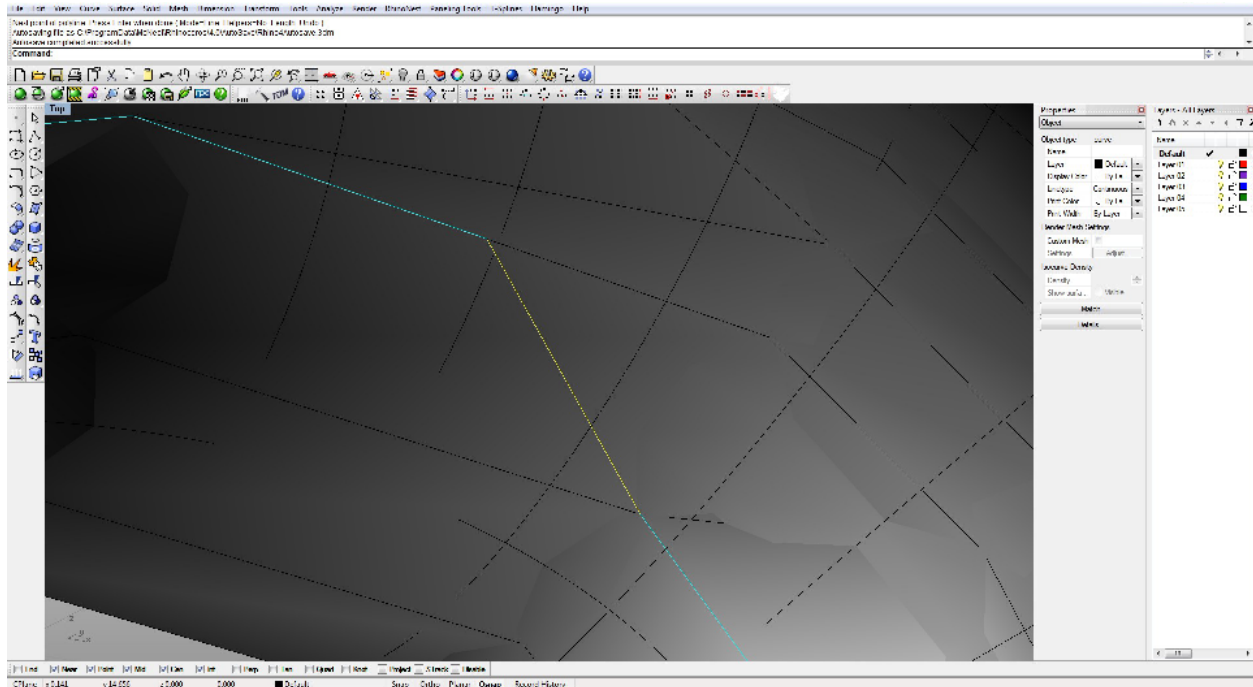

Once we've fixed all of these spots we can start lofting our parting plane.

Lofting Complex Parting Planes

We can start by trying to loft a parting plane in the same way as the sphere. First draw a square defining the parting plane at the outside of the mold:

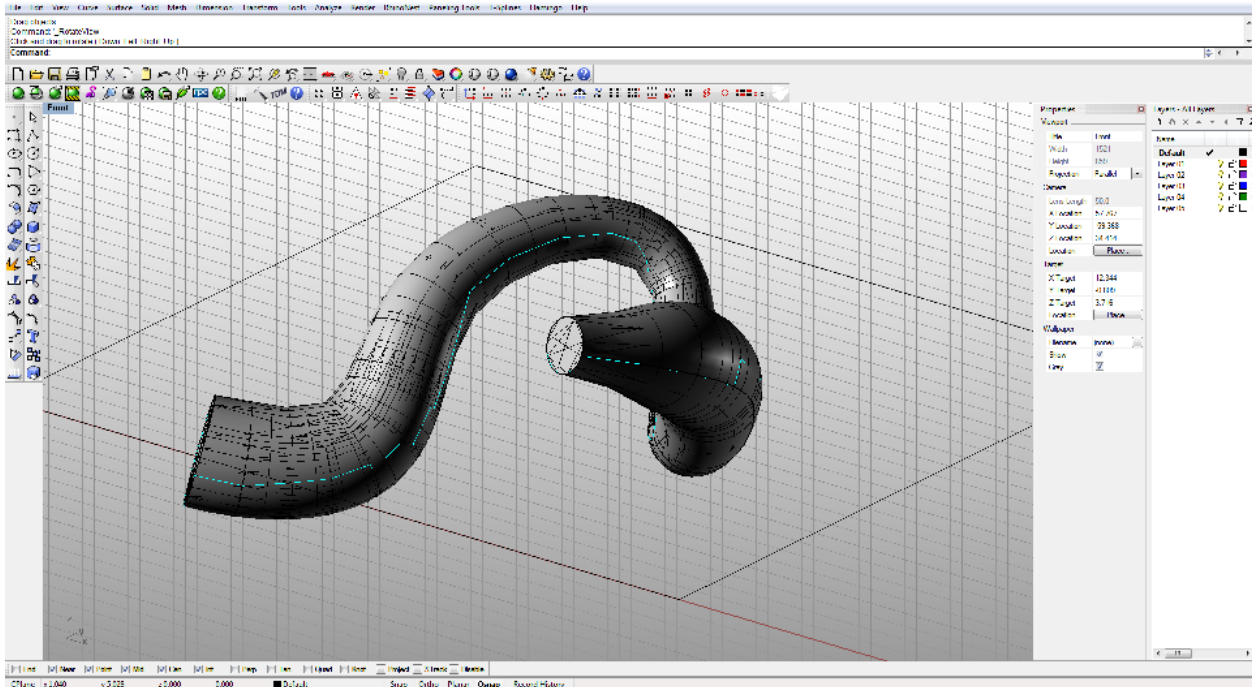

The parting line at the outside of the mold doesn't have to be flat and I can see that in this case it makes sense to make some adjustments to the level of this line. In the **Front** view and with **Osnap** disabled you can turn on the **control points** for your rectangle. Hold down the **shift key** and move the corners of the box up or down so that they mirror the level of the parting line on your object:

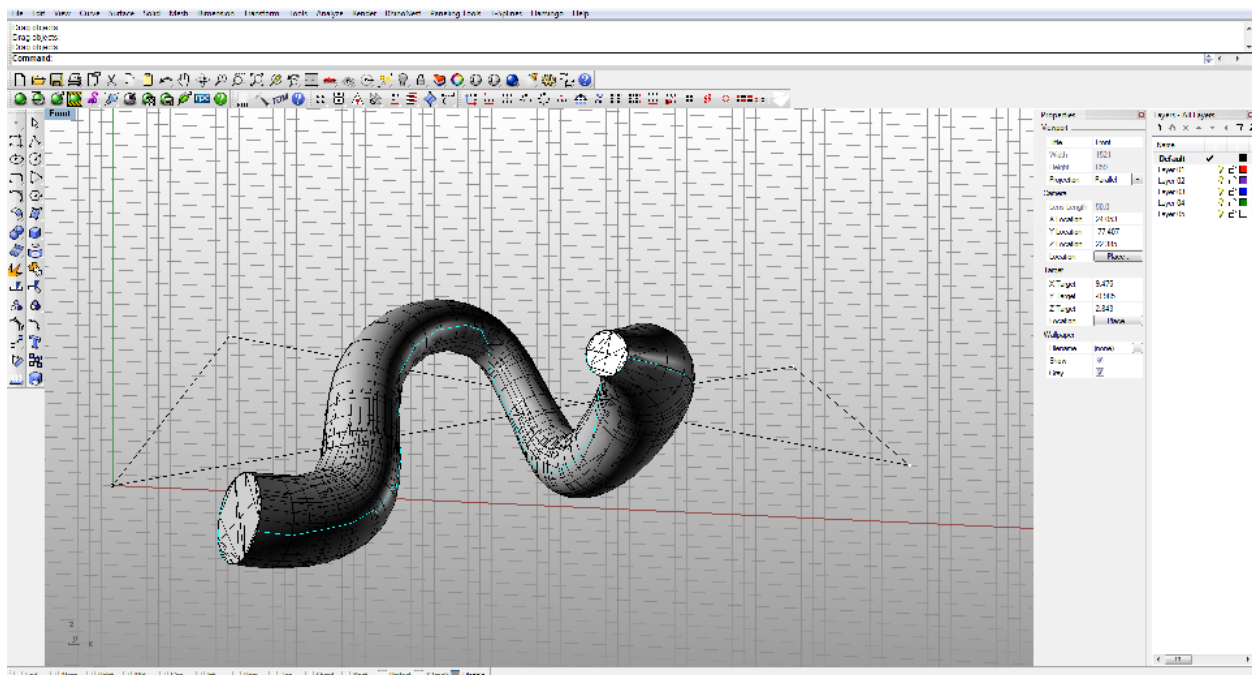

Resources:

Parting Plane Logic - 2 Part Molds (Rhino + CNC Mill)

Now let's see what happens if we loft a parting plane between these 2 curves:

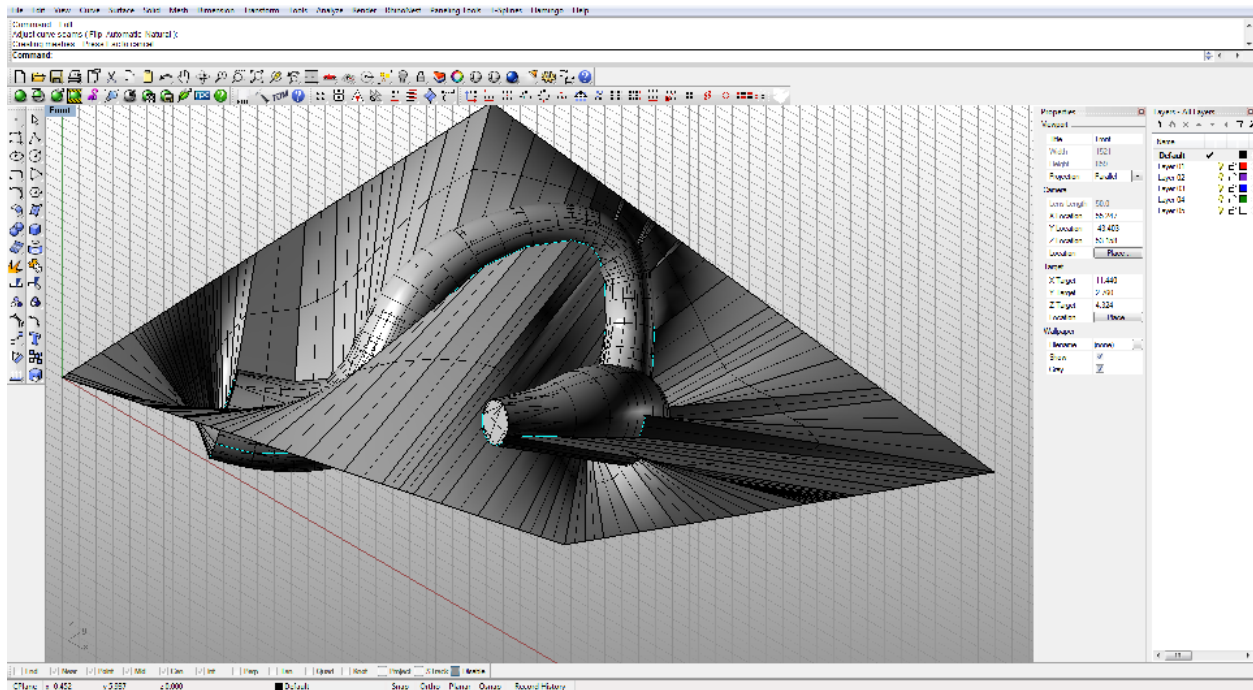

Undo the loft and we'll make some adjustments to the way the surface is going to loft. We need to think a bit about how the loft command is working. Specifically where exactly do we want the curves of the inner parting line to connect to the curves of the outer parting line.

First, because this is a sort of horseshoe shape it has a kind of inside and an outside. We want the inner parting line on the outside of the form to connect to 3 sides of the outer parting line. We can split the inner parting line and the outer parting line at these points and then loft these 2 curves:

Resources:

Parting Plane Logic - 2 Part Molds (Rhino + CNC Mill)

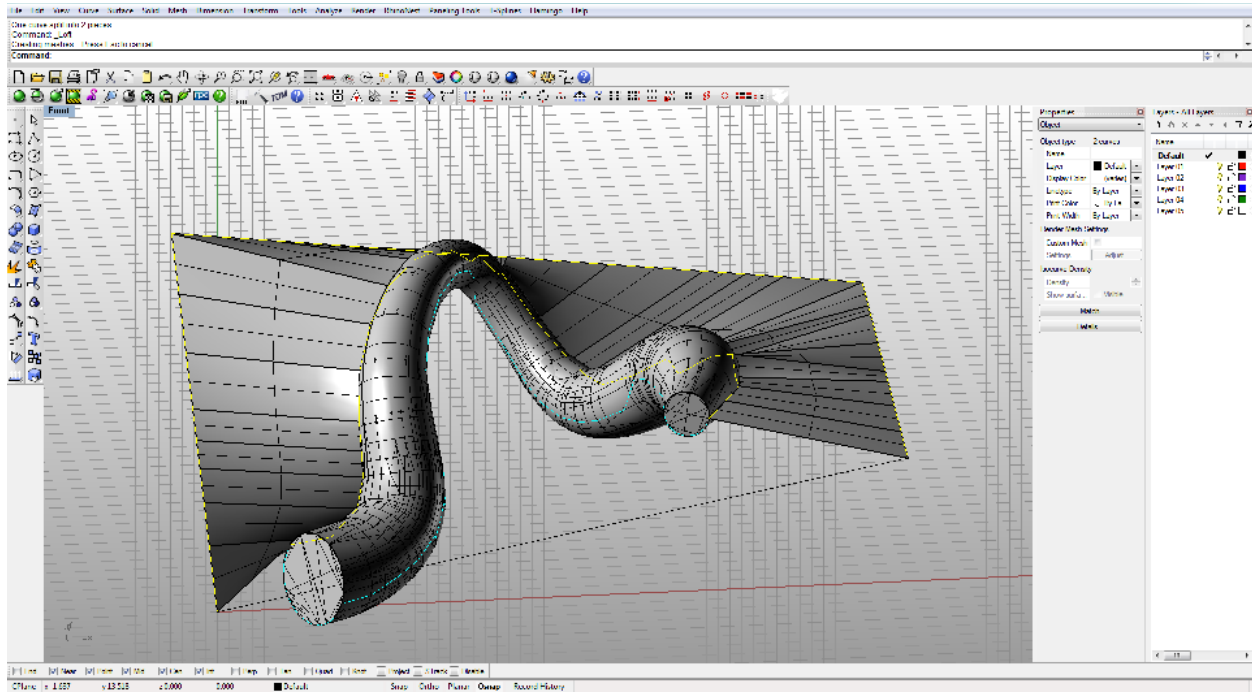
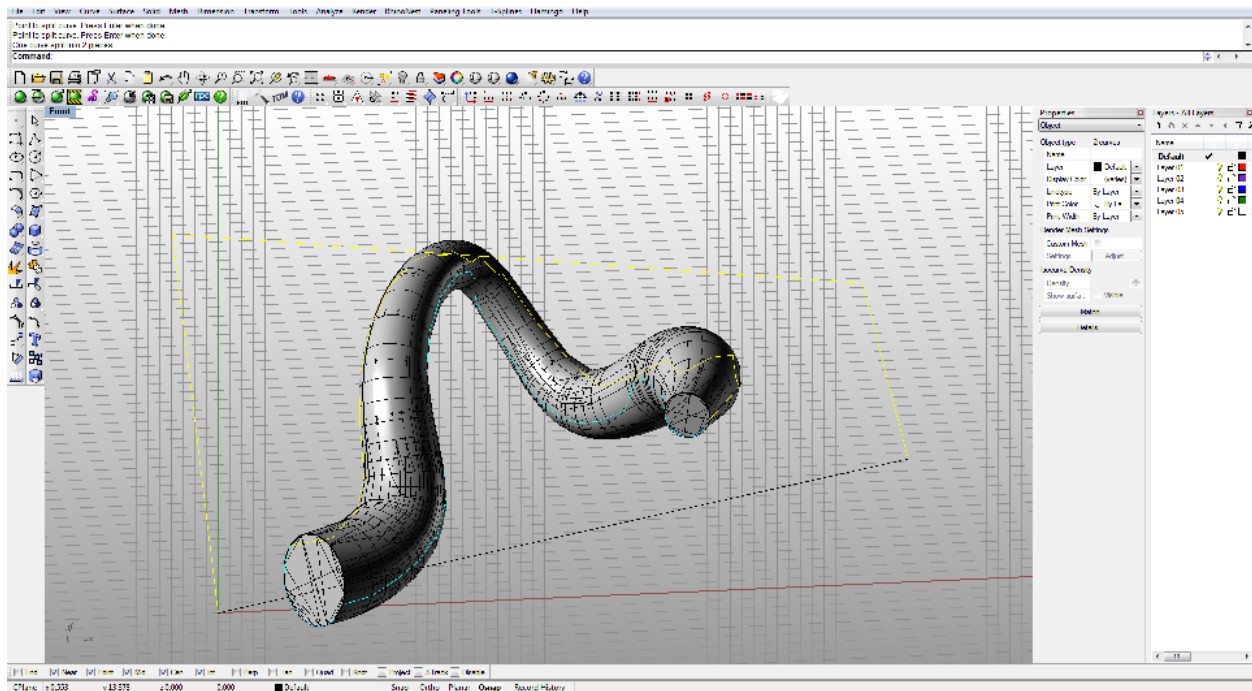

Resources: Parting Plane Logic - 2 Part Molds (Rhino + CNC Mill)

We'll loft the "inner" parting plane in a few parts. First we'll separate the inner parting line (**_Split - Point**) and then draw a line enclosing closing the interior of the form:

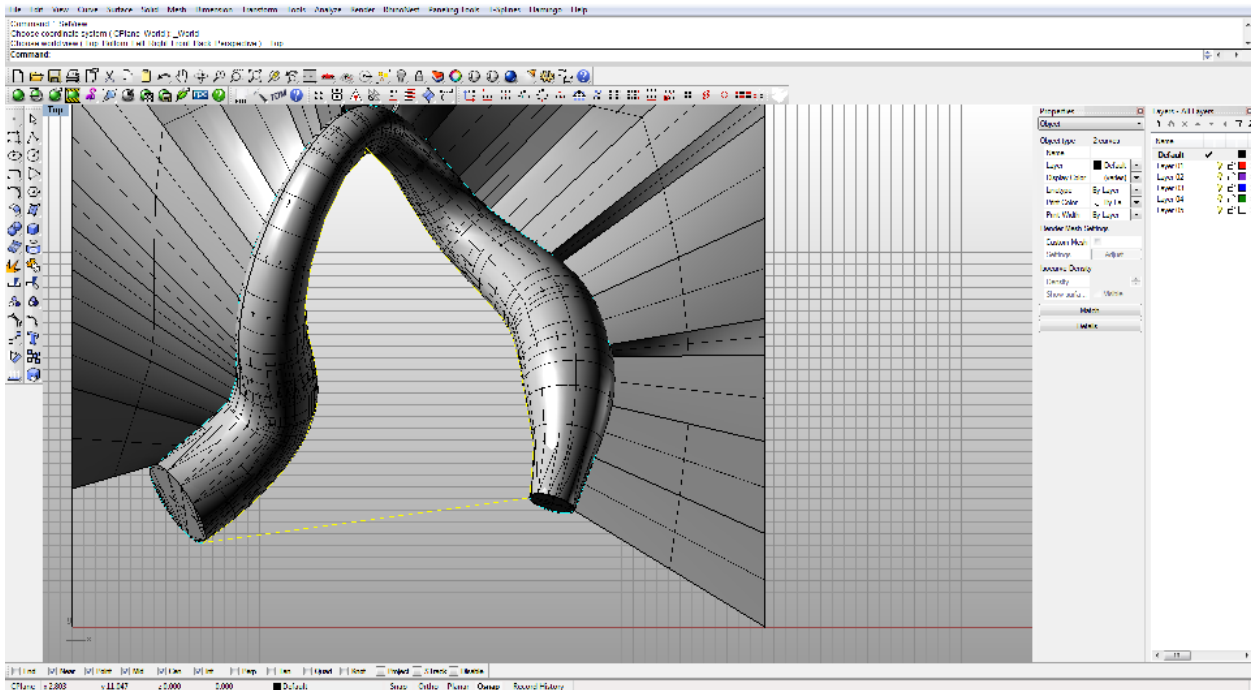

Then I'll draw another line roughly at the mid point of this curve:

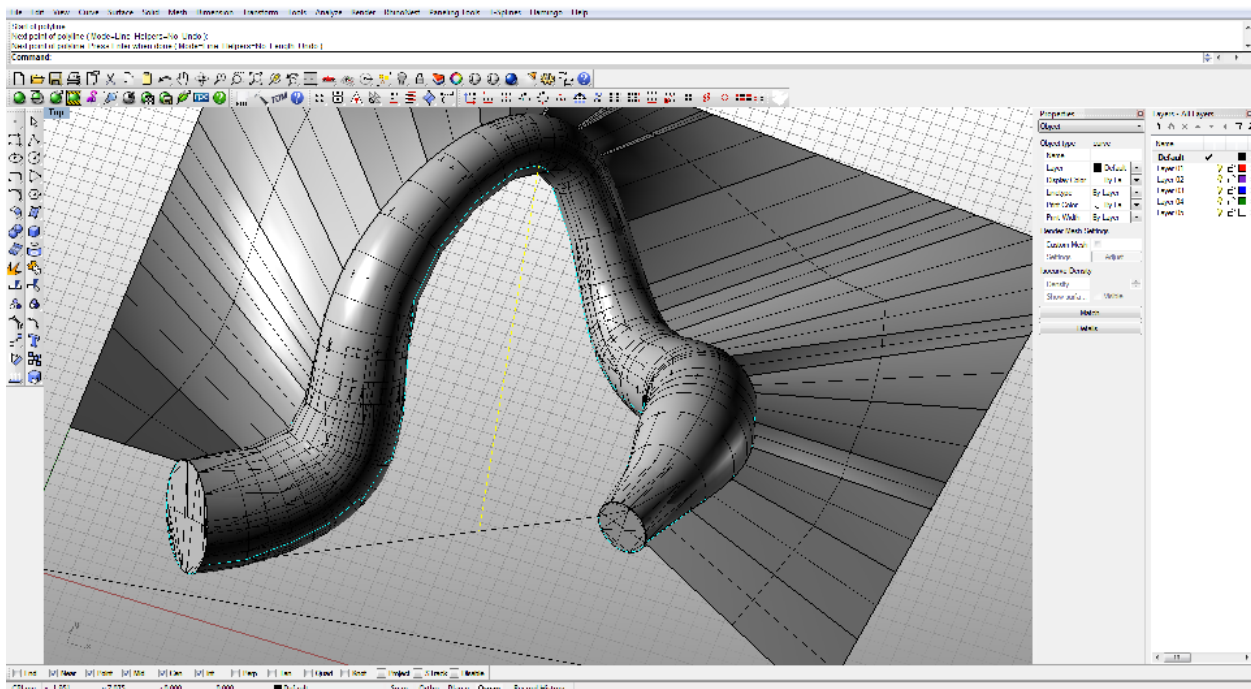

We'll now split the interior parting line at the end of this last line and then start lofting the sections:

Resources:

Parting Plane Logic - 2 Part Molds (Rhino + CNC Mill)

1.

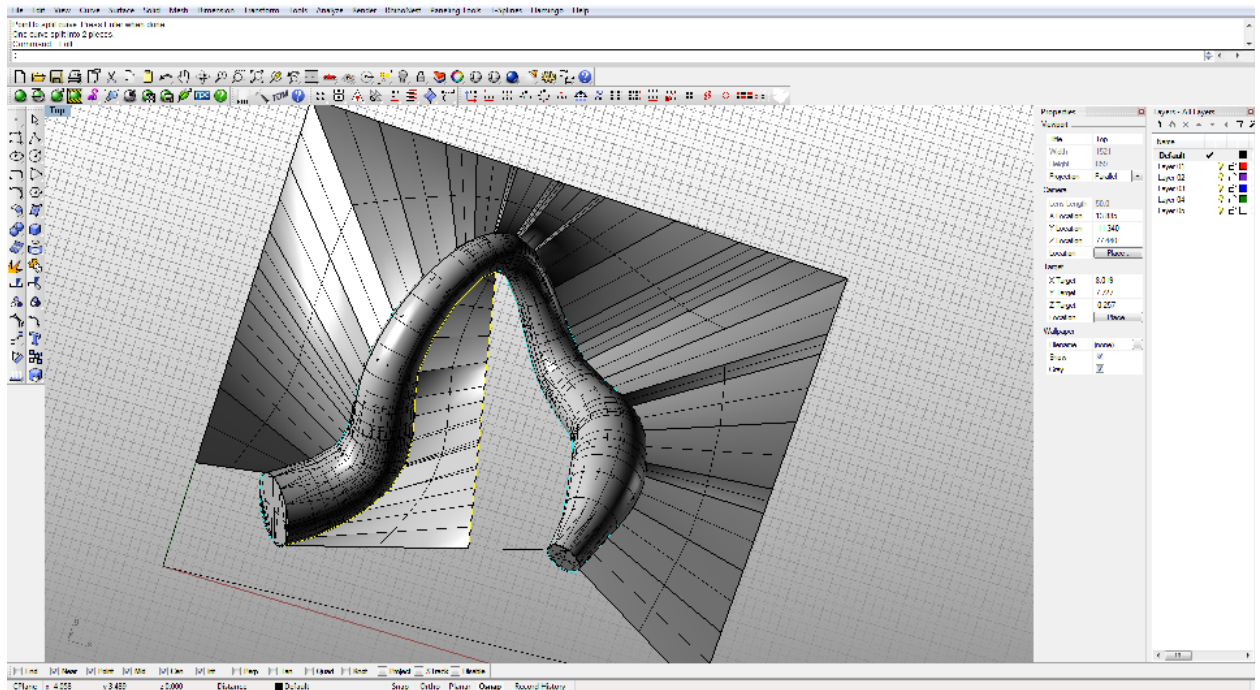

2.

